

# MF Series

## 液位浮球開關



- 動作部件少，磁簧開關接點壽命長
- 高穩定性，高可靠性
- 可依據客戶需求實現多點控制
- 安裝與維修保養簡易
- 依現場環境與流體不同，可選擇不同材質的浮球、接線盒與接續，搭配出多樣的產品
- 不適用於含有大量雜質之液體，如生活廢水；或黏性較高之液體

### 一般規格

接點形式：SPST

接電容量：AC 250V 3A, DC24V 3A以下

耐溫：SUS316L：Max. 100°C

PP：Max. 70°C

PVDF：Max. 100°C

耐壓：SUS316L：Max. 15kg/cm<sup>2</sup>

PP / PVDF：Max. 2kg/cm<sup>2</sup>





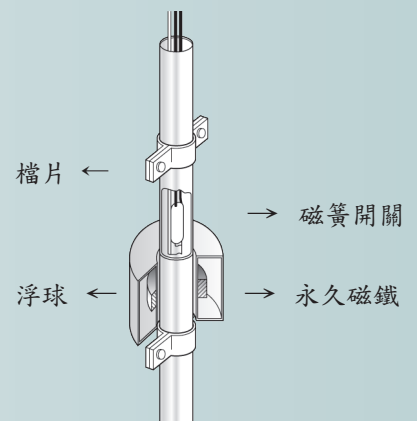

精度：±2mm

### 工作原理

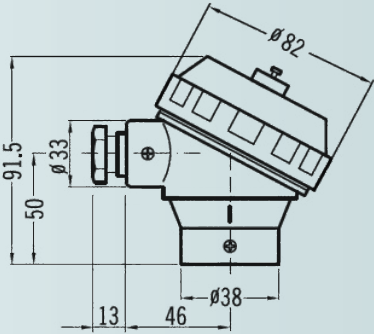
連桿式液位計又稱浮球液位開關。根據客戶的需求，在管內設置一點或多點磁簧開關，再將中空而內部有永久環型磁鐵的浮球固定於桿徑內的磁簧開關相關位置上，使浮球在一定範圍內上下浮動，利用浮球內的磁鐵去吸引磁簧開關的閉合，產生開關動作，以控制液位。

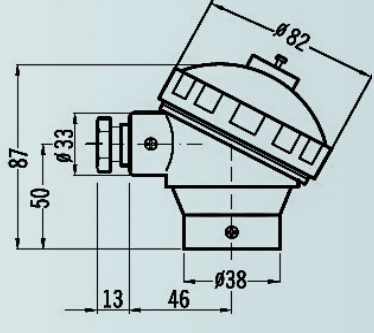

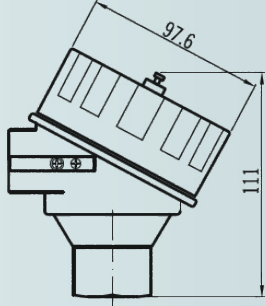
## MF系列接線盒型式

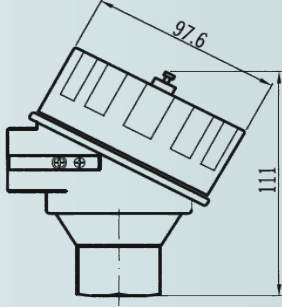
GA	尺寸圖	規格
		材質: Aluminum Alloy 防護等級: IP67 出線口: 1/2"(PF, NPT, BSP) 3/4"(PF, NPT, BSP) M20 x1.5
		材質: Polypropylene 防護等級: IP65 出線口: 3/4"NPT, M20 x1.5
		材質: Aluminum Alloy 防護等級: IP65 防爆等級: Class I, Div 1, Group A B C D, T6 出線口: 1/2"NPT, 3/4"NPT M20 x1.5
		材質: SUS316 防護等級: IP65 防爆等級: Class I, Div 1, Group A B C D, T6 出線口: 1/2"NPT, 3/4"NPT M20 x1.5

## MF系列浮球型式

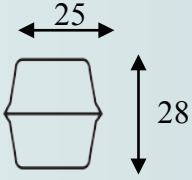
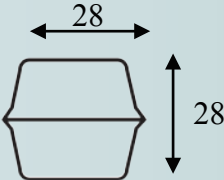
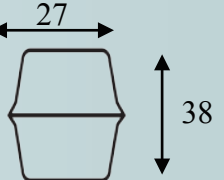
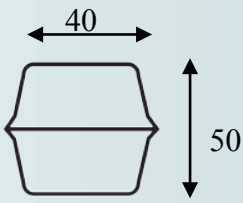
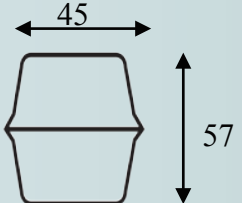
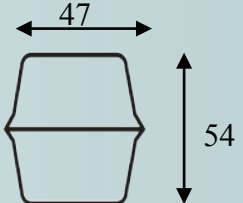
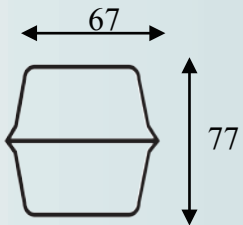
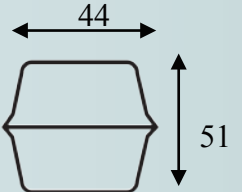
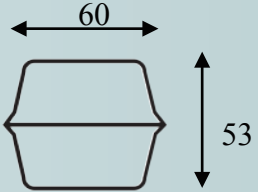
編號	6A	6B	6C
尺寸圖			
材質	SUS316L	SUS316L	SUS316L
尺寸	Ø25 x H28mm	Ø28 x H28mm	Ø38 x H27mm
耐溫	Max. 180°C	Max. 180°C	Max. 180°C
耐壓	Max. 15kg/cm <sup>2</sup>	Max. 15kg/cm <sup>2</sup>	Max. 15kg/cm <sup>2</sup>
適用比重	> 0.9	> 0.8	> 0.7
編號	6D	6E	6F
尺寸圖			
材質	SUS316L	SUS316L	SUS316L
尺寸	Ø40 x H50mm	Ø45 x H57mm	Ø47 x H54mm
耐溫	Max. 180°C	Max. 180°C	Max. 180°C
耐壓	Max. 15kg/cm <sup>2</sup>	Max. 15kg/cm <sup>2</sup>	Max. 15kg/cm <sup>2</sup>
適用比重	> 0.6	> 0.5	> 0.5
編號	6G	PP	TF
尺寸圖			
材質	SUS316L	Polypropylene	PVDF
尺寸	Ø67 x H77mm	Ø44 x H51mm	Ø60 x H53mm
耐溫	Max. 180°C	Max. 70°C	Max. 120°C
耐壓	Max. 15kg/cm <sup>2</sup>	Max. 2kg/cm <sup>2</sup>	Max. 2kg/cm <sup>2</sup>
適用比重	> 0.45	> 0.8	> 0.8

## 型號選擇

MF - 接線盒 - 浮球 - 尺寸 - 接續 - 開關型式 - 長度 - 設定點

接線盒 Housing			
<b>GA</b>	Aluminum Alloy, IP67		
<b>GP</b>	PP, IP65		
<b>EA</b>	Aluminum Alloy, IP65, Class I, Div 1, Group A B C D, T6		
<b>EP</b>	SUS316, IP65, Class I, Div 1, Group A B C D, T6		
<b>NE</b>	無接線盒		
浮球 Float			
<b>6A</b>	Ø25 x H28mm, SUS316L	<b>6F</b>	Ø47 x H54mm, SUS316L
<b>6B</b>	Ø28 x H28mm, SUS316L	<b>6G</b>	Ø67 x H77mm, SUS316L
<b>6C</b>	Ø38 x H27mm, SUS316L	<b>PP</b>	Ø44 x H51mm, Polypropylene
<b>6D</b>	Ø40 x H50mm, SUS316L	<b>TF</b>	Ø60 x H53mm, PVDF
<b>6E</b>	Ø45 x H57mm, SUS316L	<b>R</b>	Other
尺寸 Size			
<b>1</b>	1/8"	<b>7</b>	1-1/2"
<b>2</b>	1/4"	<b>8</b>	1-1/4"
<b>3</b>	3/8"	<b>9</b>	2"
<b>4</b>	1/2"	<b>10</b>	2-1/2"
<b>5</b>	3/4"	<b>11</b>	3"
<b>6</b>	1"	<b>12</b>	4"
接續 Connection			
<b>A1</b>	ANSI 150Lb	<b>P6</b>	PN10
<b>A2</b>	ANSI 300Lb	<b>W7</b>	NPT
<b>J3</b>	JIS 5K	<b>W8</b>	PT
<b>J4</b>	JIS 10K	<b>W9</b>	PF
<b>P5</b>	PN6	<b>R</b>	Other
開關型式 Switch			
<b>A</b>	SPST (N.O.)		
<b>B</b>	SPST (N.C.)		
<b>C</b>	4-20mA		
長度 Length			
<b>XXXX</b>	100mm~5000mm(接續法蘭/牙口以下算起)		
設定點數量 Setpoint			
<b>XX</b>	01~05		

**Hsiung Mei** 雄鎂科技儀器企業有限公司

台北市文山區光輝路21巷24號1樓

電話/(02)2937-1325

網址: www.hsiungmei.com.tw

傳真/(02)2937-1305

信箱: sales@hsiungmei.com.tw

▶ 營業項目 - 工業儀器與校正服務

● 液位 ● 料位 ● 壓力 ● 流量 ● 溫度 ● 記錄器