



ALIADPFLOW

Smart Transmitter for Differential Pressure Flowmeter

Model APT9500HM Series

GENERAL

ALIADPFLOW The APT9500HM Series is a transmitter of differential pressure flowmeter. Differential pressure can be converted into flow value via microcomputer technology and flowrate, totalizer. The differential pressure can be displayed directly in LCD screen. It's equipped with strong output function: 4-20 mA, pulse and HART. APT9500HM is widely used in differential pressure sensors flowmeter such as orifice, venturi, annubar, v-cone etc. It has high stability and high accuracy.

FEATURES

- Converter can be rotated at six directions for easy installation
- Can display flow rate, totalizer and differential pressure at the same time
- Two years stability of 0.2%
- 0.075% accuracy
- Parameter setting by keypad directly
- 4-20 mA and pulse output, HART communication
- Automatic zero calibration by press-button
- Explosion Proof and weather proof housing

STANDARD SPECIFICATION

- Process Fluid : Liquid, Gas, Vapor
- Application : Differential pressure flow measurement
- Pressure Range : 0-2500 kPa
- Flow Range : 0-999999
- Turndown Ratio : 20:1
- Accuracy : +/-0.075% of span
- Stability : +/-0.15% of URL for 2 years
- Working Temperature : -25~95 °C
- Max. Pressure : 40 MPa
- Material
 - Flange / Adapter : Stainless Steel 304 / Stainless Steel 316
 - Drains / Vents : Stainless Steel 304 / Stainless Steel 316
 - Diaphragm : Stainless Steel 316L / Hastelloy B / Hastelloy C / Monel / Tantalum
 - Wetted O-Ring : Buna N / Viton / PTFE
 - Bolts & Nuts : Carbon Steel / Stainless Steel 316
 - Mounting Bracket : Carbon Steel / Stainless Steel 304 / 316
 - Name / Tag Plate : Stainless Steel 304 / Stainless Steel 316
 - Converter Housing : Low copper cast aluminum alloy with polyurethane, light blue paint
- Fill Fluid : Silicone Oil / Fluorine Oil
- Protection Class : IP67 (Standard)
 - : Intrinsically Safe, Eex ia IIC T5 (Standard)
 - : Explosion Proof, Ex d IIB T5 (Optional)
- Mounting : Direct Mounting / Bracket on 2" Pipe
- Display : 9-Digit totalizer, 6-Digit flow rate
- Display Unit : 32 Flow engineering unit
5 Digits programmable for special unit
- Keypad : 3 Internal keys for programming and output setting
- Current Output : 4-20 mA (2 wires)
with HART signal (Compatible)
Load : Rohm= (VDC-9) * 50
- Pulse Output : Scaled Pulse
- Power Supply : 9-36 VDC
- Damping : 0-32 Seconds
- Humidity Limit : 0-100% Relative Humidity
- Turn on Time : 2 Seconds with minimum damping
- Zero Calibration : Automatic zero calibration by press-button
- Cable Entry : M20 Conduit Threads / 1/2" NPT (Female)
- Temperature Effect : +/-0.18% of span per 20 °C
- Vibration Effect : +/-0.05% of URL per g to 200 Hz in any axis
- EMI / RFI Effect : Follow SAMA PMC 33.1 from 20-1000 MHz and for field strengths up to 30 V/m
- Process Connection : 1/4-18 NPT
: 1/2-14 NPT (with adapter)
- Ambient Temperature : -25~80 °C
- Dimensions : 102 mm (W) * 188 mm (H) * 130 mm (D)
- Weight : 3.5 kg



ALIA TECHNOLOGY LLC

633 W. 5th Street, 26th Floor, Los Angeles, CA 90071, USA
TEL : + 1 - 213 - 533 - 4139 FAX : + 1 - 213 - 223 - 2317



URL : www.alia-inc.com
E-mail : alia@alia-inc.com
APT9500HMV1.2.3.A4.en



MEASURING RANGE

Range Code	Pressure Range			
	Low Range	High Range	Low Range	High Range
2	0-0.16 kPa	0-1.0 kPa	0-16.32 mmH ₂ O	0-102.0 mmH ₂ O
	0-1.6 mbar	0-10 mbar	0-0.6423 inH ₂ O	0-4.015 inH ₂ O
	0-0.023 psi	0-0.145 psi	0-0.001 kgf/cm ²	0-0.010 kgf/cm ²
3	0-1.0 kPa	0-6.0 kPa	0-102.0 mmH ₂ O	0-611.82 mmH ₂ O
	0-10 mbar	0-60 mbar	0-4.015 inH ₂ O	0-24.088 inH ₂ O
	0-0.145 psi	0-0.87 psi	0-0.010 kgf/cm ²	0-0.061 kgf/cm ²
4	0-6.0 kPa	0-40 kPa	0-611.82 mmH ₂ O	0-4078 mmH ₂ O
	0-60 mbar	0-400 mbar	0-24.088 inH ₂ O	0-160.6 inH ₂ O
	0-0.87 psi	0-5.802 psi	0-0.061 kgf/cm ²	0-0.408 kgf/cm ²
5	0-40 kPa	0-200 kPa	0-4.079 mH ₂ O	0-20.39 mH ₂ O
	0-400 mbar	0-2000 mbar	0-160.6 inH ₂ O	0-802.9 inH ₂ O
	0-5.802 psi	0-29.0 psi	0-0.408 kgf/cm ²	0-2.039 kgf/cm ²
6	0-160 kPa	0-1000 kPa	0-16.32 mH ₂ O	0-101.97 mH ₂ O
	0-1.6 bar	0-10 bar	0-642.3 inH ₂ O	0-4014 inH ₂ O
	0-23.21 psi	0-145 psi	0-1.632 kgf/cm ²	0-10.197 kgf/cm ²
7	0-400 kPa	0-2500 kPa	0-40.79 mH ₂ O	0-254.9 mH ₂ O
	0-4.0 bar	0-25 bar	0-1605 inH ₂ O	0-10036 inH ₂ O
	0-58.02 psi	0-362.6 psi	0-4.079 kgf/cm ²	0-25.49 kgf/cm ²

WIRING DIAGRAM

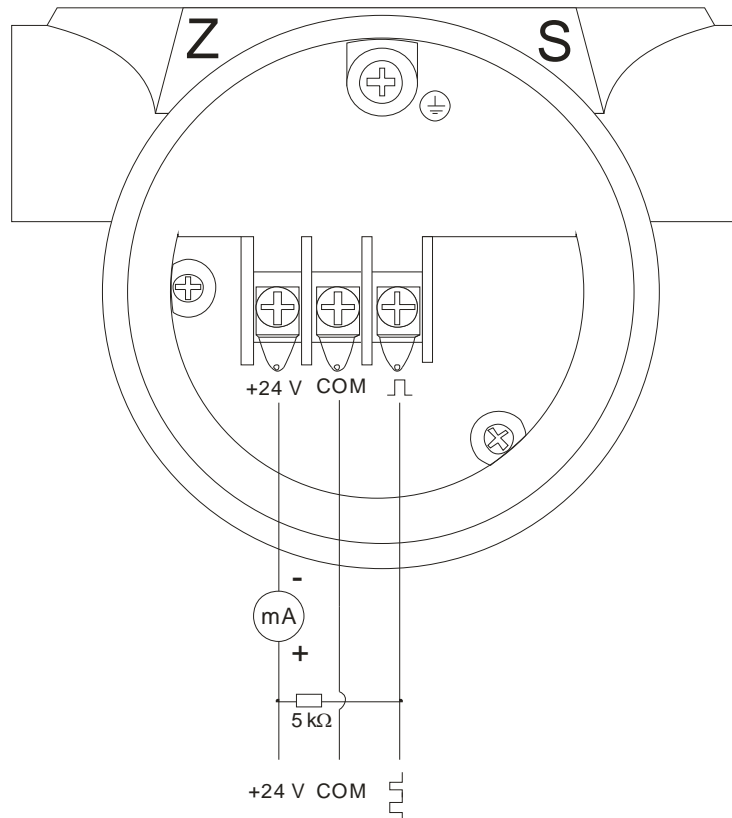

DIMENSIONS

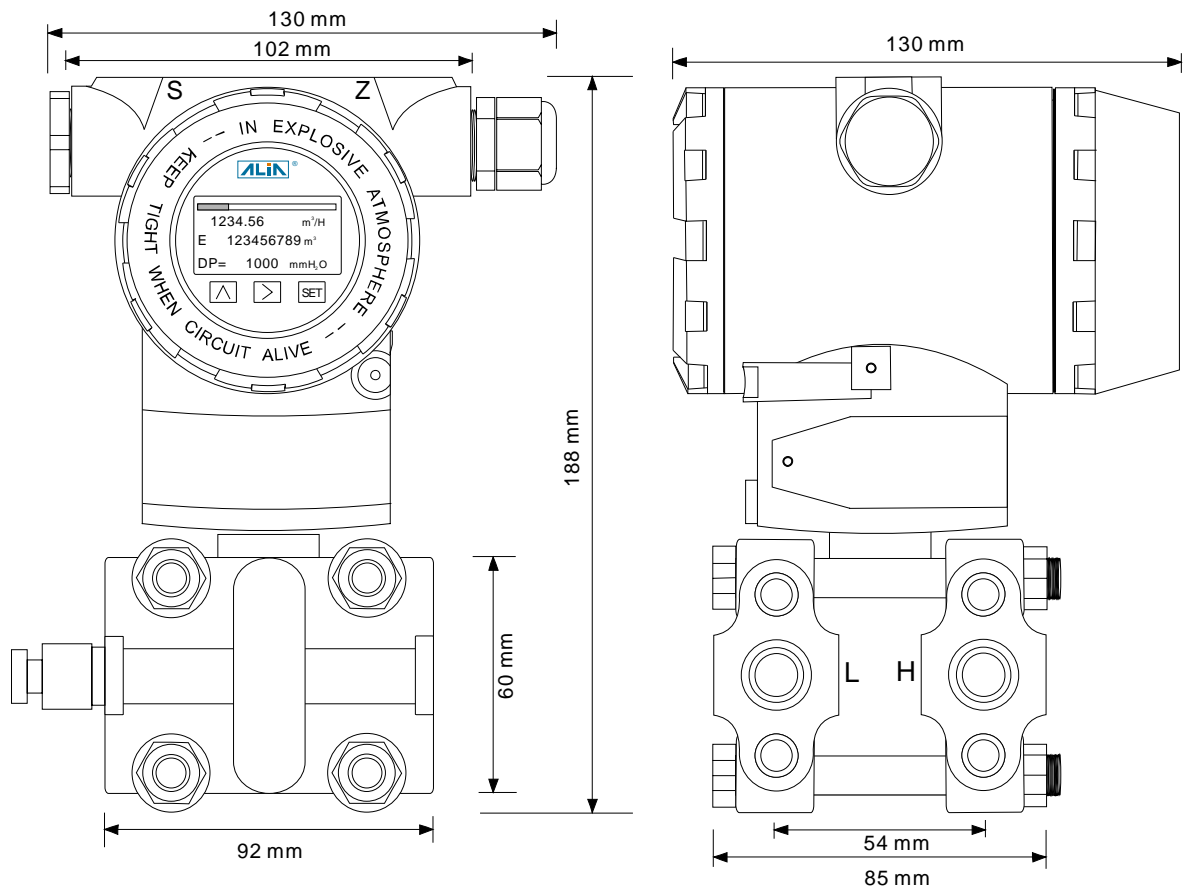

APPLICATION EXAMPLES



MODEL SELECTION GUIDE

APT9500HM Series												
Example: APT9500HM-3-CNS-6NF-NNN-EX/S6												
APT9500HM-	X	-X	X	X	-X	X	X	-X	X	X	-XX	Description
Pressure Range	2											0-0.16 (0.01) kPa ... 0-1.0 kPa
	3											0-1.0 (0.06) kPa ... 0-6.0 kPa
	4											0-6.0 (0.4) kPa ... 0-40 kPa
	5											0-40 (2.0) kPa ... 0-200 kPa
	6											0-160 (10.0) kPa ... 0-1000 kPa
	7											0-400 (25.0) kPa ... 0-2500 kPa
Diaphragm Material	-N											Stainless Steel 316L
	-B											Hastelloy B
	-C											Hastelloy C
	-P											Monel
	-T											Tantalum
Process Flanges, Drain / Vent valve Material	N											Stainless Steel 304
	S											Stainless Steel 316
Bolts / Nuts Material	N											Carbon Steel
	S											Stainless Steel 316
Mounting Bracket Material	-N											Carbon Steel
	-4											Stainless Steel 304
	-6											Stainless Steel 316
	-X											Direct mounting, without 2" Mounting Bracket
Wetted O-ring Material	N											Buna-N
	V											Viton
	P											PTFE
Fill Fluid	N											Silicone Oil
	F											Fluorine Oil
Process Connection	-N											1/4"-18 NPT
	-A											1/2"-14 NPT (with Adapter)
	-Z											Other
Cable Entry	N											M20 Conduit Threads
	P											1/2" NPT (Female)
	Z											Other
Maximum Pressure Limit	N											4 MPa
	1											6.4 MPa
	2											16 MPa
	3											40 MPa
Option	-NN											None
	-EX											Explosion Proof, Ex d IIB T5
	-S6											Stainless Steel 316 Name Plate and Tag Plate
	-HT											HART Signal (Compatible)
	-RS											Customized range setting
	-RC											Customized range calibration
	-ZZ											Others