

Technical Datasheet



MCU200: Controller and Sensors

Suspended solids detection for Liquid Level Control

Model: MCU200 series

Key Features

- Ultrasonic technology
- Level or interface detection
- Oil in Water or Water in Oil detection
- Choice of sensors for tanks or pipes
- LED indication for Normal, Alarm and Fault
- DPDT relay output, configurable for wet to dry, or dry to wet changeover
- Cable check fault detection
- Configurable time delay
- Unaffected by liquid colour/opacity, or conductivity
- Wall mounting IP65 polycarbonate enclosure

Product Overview

The MCU200 series is comprised of a controller and gap sensor. The ultrasonic signal from the sensor is affected by the liquid within the sensor gap. Ultrasonic point level switches may be used in industrial processes to detect high or low liquid levels or liquid interfaces, such as a sludge blanket. They can also discriminate between liquid and air, or immiscible liquids such as oil and water. They are therefore commonly used to detect a rising sludge blanket level in settlement tanks, and for oil or water contamination detection in marine and other industries.

Other related products include:

- MSM400 for continuous sludge density measurement with 4-20mA, HART and relay outputs
- DMSP ultrasonic level transmitters



Product applications

- Liquid level detection
- Sludge level detection
- Settlement tank high level alarm
- Water in oil / oil in water detection
- Interface detection between two immiscible liquids
- Sensors for use in tanks or pipes

How can we help you?

Delta Mobrey offers fast, efficient and knowledgeable support when and where you need it. Please visit our web site at www.delta-mobrey.com to find your local support centre or call us on:

+44 (0)1252 729140

Principles of Operation

Ultrasonic technology can be used to discriminate between immiscible liquids to indicate an interface or to detect suspended solids. It is helpful to understand the operating principles in order to select the most suitable sensor.

Sludge detection (sensors 433SD and 442SD)

Solids suspended in a liquid will scatter ultrasonic beams causing attenuation. This attenuation depends on the size and nature of the particles.

For typical sewage sludges, the ultrasonic sensors can detect 1% to 30% suspended solids within a slurry. Industrial slurries such as fine pottery slips can often be measured up to 65% solids by weight.

The 433SD sensor is normally suspended in a settlement tank or separator.

The 422SD sensor pair is typically installed across a pipe.

Interface detection (sensor 402SD)

For interface detection between two immiscible liquids, two techniques are available: *ultrasonics attenuation* and *ultrasonic refraction*.

Ultrasonic attenuation is the reduction in signal energy as it is transmitted through the liquid. Viscous liquids, emulsions and liquids with entrained solids generally have a higher ultrasonic attenuation than low viscosity clear liquids such as water. When the attenuation difference is sufficient, the amplifier gain can be adjusted so that the ultrasonic signal passes through the less attenuative liquid but is stopped by the more attenuative liquid.

The refraction technique is used to detect the interface where two immiscible liquids have similar attenuations. When the sensor is oriented at an angle of 10 degrees from horizontal, and the interface level is within the gap of the sensor, a small signal is received. The gain of the MCU200 control unit can be set to activate the relay when little signal is received.

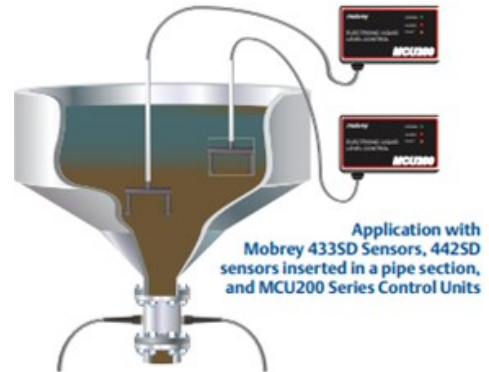
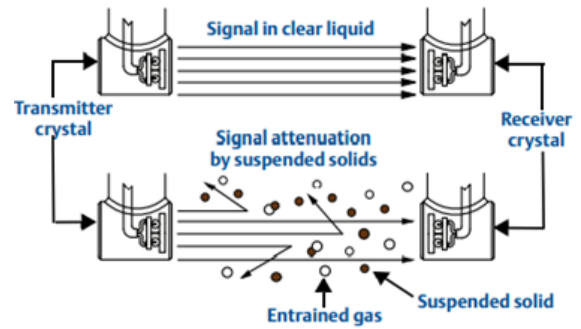

INTERFACE DETECTION BY ATTENUATION

Sensor in oil:
The ultrasonic beam is attenuated and will not reach the receiver crystal

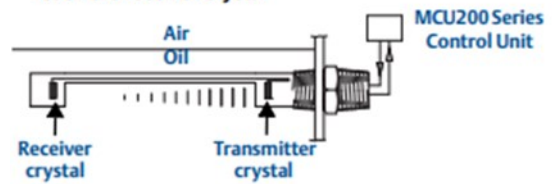

Sensor in water:
The ultrasonic beam reaches the receiver crystal

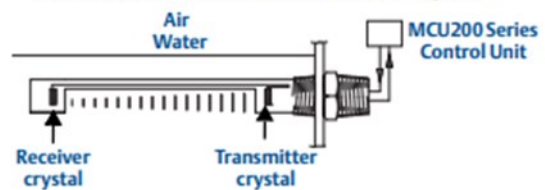

INTERFACE DETECTION BY REFRACTION

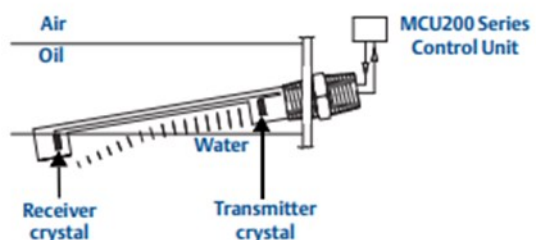
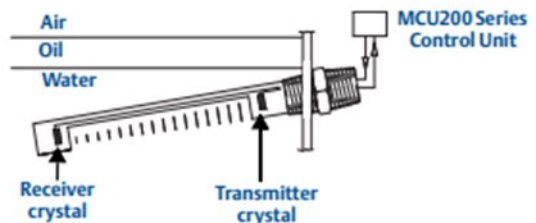

Suspended Solids Detection
Models: MCU200

Technical Specification

MCU200 Series Controller	MCU201		MCU203
Power supply	110/220 Vac or 220/240 Vac selectable		24Vdc grounded (earthed) negative
Power consumption	6VA		2.4W
Number of sensor inputs	One		
Relay output	Double-Pole Changeover (DPDT)		
	Energised when sensor is wet or dry (configurable)		
Relay rating	5A at 230V		
Enclosure size	200 x 120 x 75mm (7.9 x 4.7 x 3.0 inches)		
Enclosure rating	IP65 Polycarbonate		
Holes for glands	3 off 16mm (0.63 inches)		
Fixing centers for wall mount	188 x 88mm W x H (7.4 x 3.4 inches)		
Fixing hole diameter	4mm (0.16 inches)		
Frequency selection	1 MHz (higher sensitivity) or 3.7 MHz (standard) by switch		
LED indicators	Green for Normal. Red for Alarm. Amber for Fault. Visible through lid.		
	Green or Red selectable for wet or dry.		
Gain setting	Range switch and gain potentiometer to adjust for sensor and application		
Response time	Selectable delay of 0.5, 2, 8 or 30 seconds		
	Delay selectable for wet-to-dry or dry-to-wet changeover		
	50ms response in opposite direction		
Sensor cable check	Selectable to monitor coax screen for continuity		
	Fault condition lights the fault LED and sets relay to alarm state		
Auxiliary Input	External closed circuit input latches the output relay to achieve pump control		
Ultrasonic gap Sensors	402SD80	433SD80	442SD80
Repeatability	2mm	2mm	2mm
Operating temperature	-70 to 150°C (-94 to 302°F)	-40 to 70°C (-40 to 158°F)	-70 to 150°C (-94 to 302°F)
Maximum pressure	105 bar (1523 psi)	105 bar (1523 psi)	105 bar (1523 psi)
Power consumption	< 10 mW at sensor	< 10 mW at sensor	< 10 mW at sensor
Standard frequency	3.7 MHz	1 MHz / 3.7 MHz	1 MHz / 3.7 MHz
Sensor cable entry	IP65	IP65	IP65
Sensor cable	PTFE-insulated dual coaxial with PVC sheaf. Minimum bend radius 35mm (1.4") Terminated with crimped ferules to connect within MCU200 controller terminals		
Note: MCU200 series controllers and the 4**SD sensors are for non-hazardous area use only			

How to order the control unit

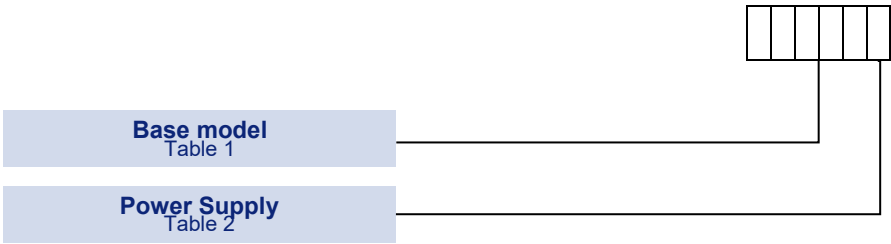

MCU Control Unit

TABLE 1 

Base Model	Code
MCU control unit, for use with all sensors	MCU20

TABLE 2 

Power Supply	Code
220/110Vac (50/60 Hz). Safe area only.	1
24Vdc. Safe area only.	3

All Ultrasonic Sensors

- All sensors can be used with the MCU200 series of controllers
- Cables are terminated with crimped ferules to connect within the MCU200 series controller
- Ultrasonic sensors should not be used in liquids with high aeration of foam which will attenuate the signal

433SD Tank Mount Sensors

433SD tank mount sensors are commonly mounted within a settlement tank from above, to detect a rising sludge blanket level

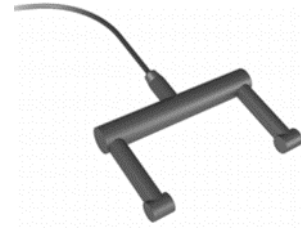

Gap Size Selection

Sensor Gap Size	Primary Sludge at 1MHz	Primary Sludge at 3.7MHz	Secondary Sludge at 3.7MHz
100 mm (4 inch)	3 to 29%	1 to 6%	2 to 15%
150 mm (6 inch)	2 to 19%	1 to 4%	1 to 10%
200 mm (8 inch)	2 to 14.5%	0.5 to 3%	1 to 7.5%
300 mm (12 inch)	1 to 10%	0.5 to 2%	0.5 to 5%
450 mm (18 inch)	N/A	0.5 to 1.3%	0.5 to 3.3%

Note: These % solids ranges are based on typical attenuation factors for municipal waste-water sludge. Within the UK's waste-water industry, experience has found a 6 inch gap sensor at 1 MHz is suitable for a majority of Primary Sludge applications, and an 18 inch gap sensor at 3.7 MHz is suitable for a majority of Secondary Sludge applications.

How to order tank mount sensors

All tank mount sensors begin 433SD, then select the gap width and the cable length.

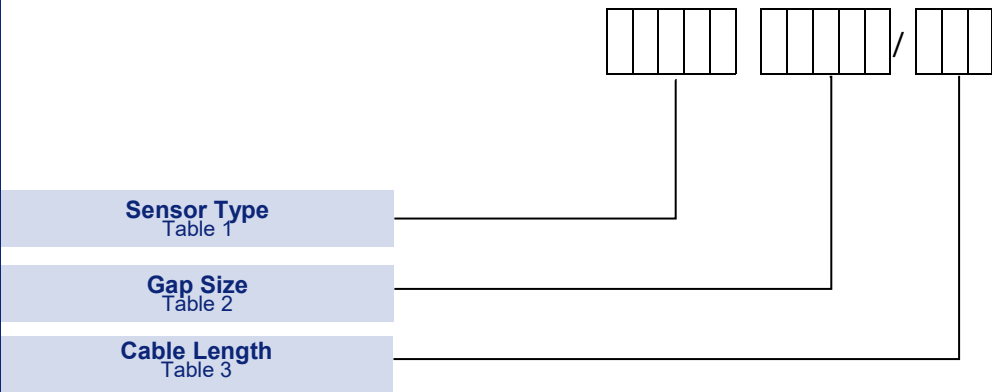

Suspended Solids Detection
Models: MCU200

Tank mount sensors

TABLE 1

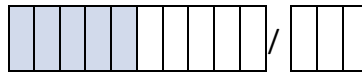

Sensor Type	Code
Tank mount sensor for MCU200 series	443SD

TABLE 2



Gap Size	Code
100mm (4 inch) tank mount gap sensor. 1 MHz / 3.7 MHz.	801M1
150mm (6 inch) tank mount gap sensor. 1 MHz / 3.7 MHz	805M1
200mm (8 inch) tank mount gap sensor. 1 MHz / 3.7 MHz.	805M1
300mm (12 inch) tank mount gap sensor. 1 MHz / 3.7 MHz.	803M1
450mm (18 inch) tank mount gap sensor. 3.7 MHz only.	804M3

TABLE 3



Cable Length	Code
Cable length 10 meters	M10
Cable length 20 meters	M20
Customer defined cable length up to a maximum of 30m (may incur a longer lead time and additional cost)	MXX

Note: the MCU200 controller can be set to operate at either 1 MHz or 3.7 MHz. The standard frequency for general operation is 3.7 MHz.

402SD interface sensors

402SD interface sensors are typically positioned either horizontally or at a 10 degree angle to detect a liquid interface.



442SD pipe mount sensors

442SD pipe mount sensors may be mounted across a pipe of from 100mm (4") to 300mm (12") diameter.



How to order interface and pipe mount sensors

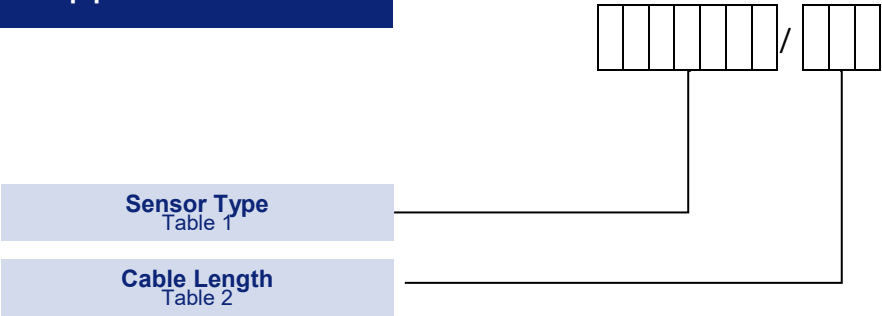

Interface and pipe mount sensors

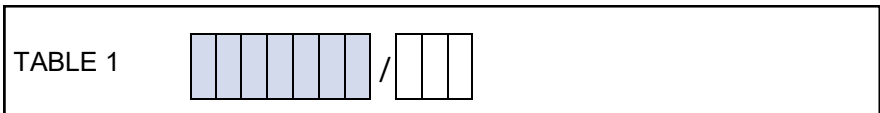

Sensor Type	Code
Interface sensor. 3.7 MHz only.	402SD80
Pipe mount sensor. 1 MHz / 3.7 MHz.	442SD80

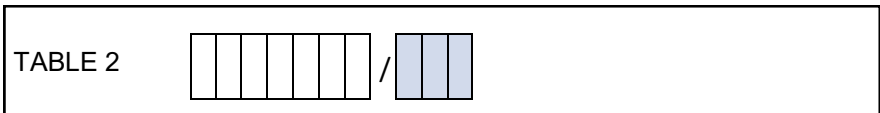

Gap Size	Code
Cable length 3 meters	M03
Cable length 6 meters	M06
Customer defined cable length up to a maximum of 30m (may incur a longer lead time and additional cost)	MXX

Approvals

EUROPEAN DIRECTIVES



Electromagnetic Compatibility Directive (EMC) 2014/30/EU

Compliant to EMC directive

Low Voltage Directive (LVD) 2014/35/EU

Compliant to LVD directive

Pressure Equipment Directive (PED) 2014/68/EU:

This product is out of the scope of the PED directive

Dimensional drawings: control unit

TOP VIEW

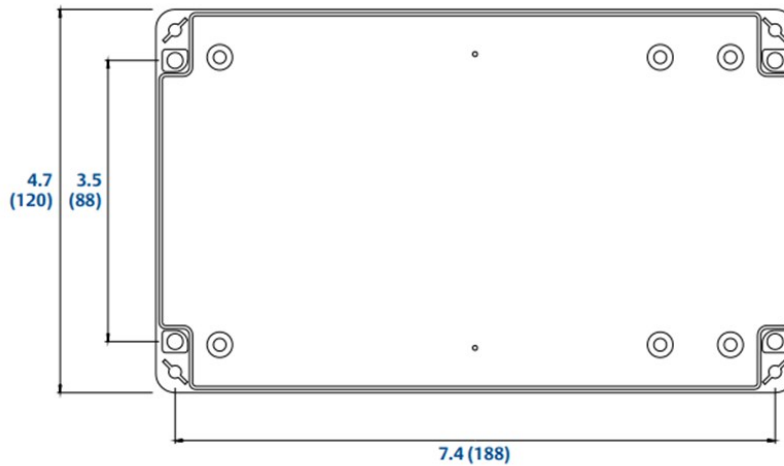

BOTTOM VIEW

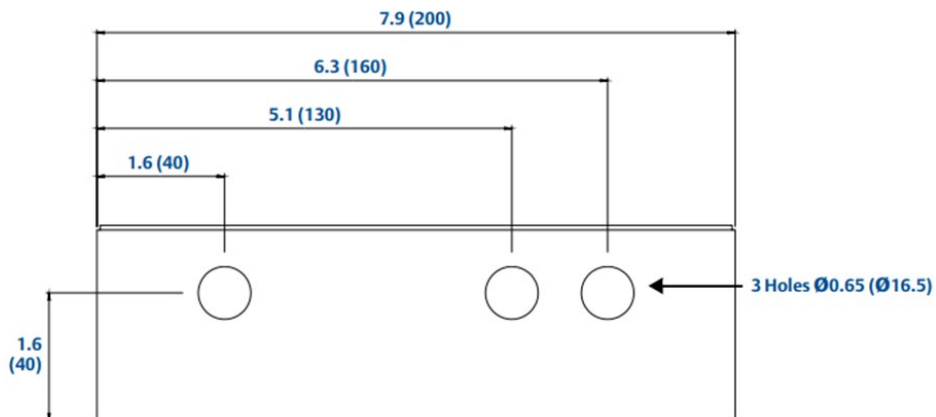

**Dimensional drawings:
sensors**

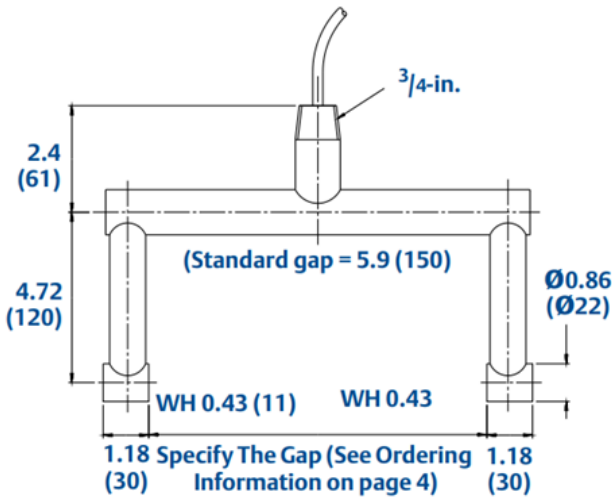

Sensor type 433SD
 316 stainless steel
 Duty: Sludge blanket or interface, immiscible liquids
 Liquid type: Viscous or with solids in suspension

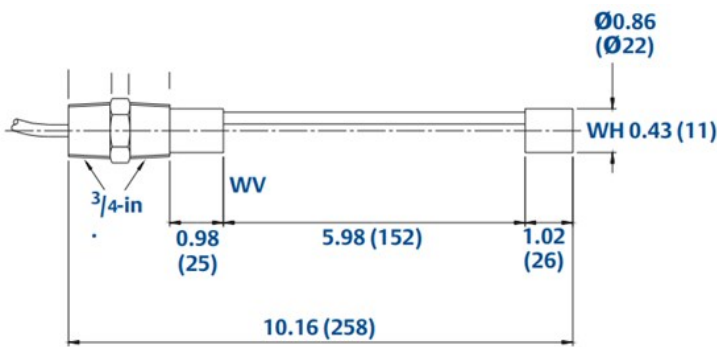

Sensor type 402SD
 316 stainless steel
 Duty: Interface, immiscible liquids
 Liquid type: Clean, viscous with solids

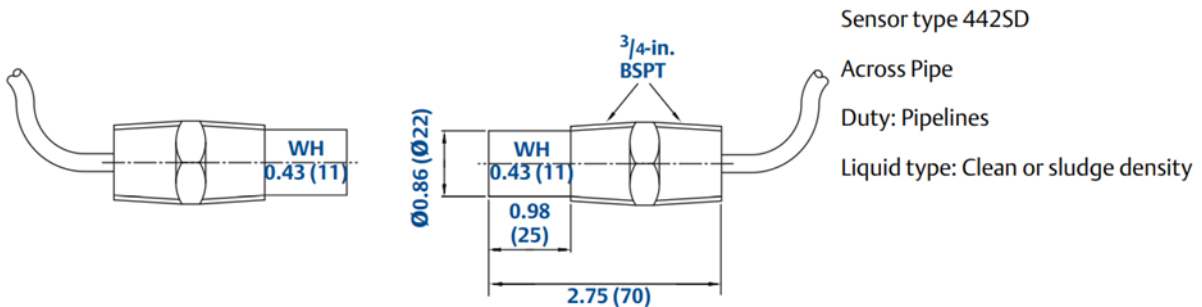

Sensor type 442SD
 Across Pipe
 Duty: Pipelines
 Liquid type: Clean or sludge density

In the interest of development and improvement Delta Mobrey Ltd, reserves the right to amend, without notice, details contained in this publication. No legal liability will be accepted by Delta Mobrey Ltd for any errors, omissions or amendments.

Delta Mobrey Limited
 Riverside Business Park, Dogflud Way, Farnham, Surrey GU9 7SS, UK.
 T+44 (0)1252 729140 F+44 (0)1252 729168 E sales@delta-mobrey.com W www.delta-mobrey.com



FM00720