

## GENERAL

**ALIARADAR** The ARL5000 Series is a radar level transmitter particularly suited for non-contact level measurement and is characterized by 26 G high frequency microwave pulse. The measurement can reach the distance of 70 m and is not affected by the influence of noise, vapor, pressure, dust, gas volatilization etc. With excellent anti-interference ability, it can work effectively in harsh environments.

Equipped with a new micro processor and optimized antennas, ARL5000 is more ideal in velocity signal analysis, processing capacity, measurement with stability and accuracy. It is perfect for level measurement control with simple structure and easy installation.

## FEATURES

- ❑ Anti-interference of noise, vapor, dust, foam, vacuum, etc
- ❑ Shorter wavelength, better reflection on inclined solid surface
- ❑ Non-contact radar, free of wear and pollution
- ❑ Small beam angle & focus energy to enhance anti-interference ability and radar echo
- ❑ High frequency, ideal for the measurement of solid and dielectric constant
- ❑ Measuring distance up to 70 m (230 ft), high accuracy of 3 mm

## STANDARD SPECIFICATION

- Measure Principle : Radar
- Measure Range : 0-70 m
- Display : 4 Digit LCD with Bargraph
- Resolution : 1 mm / 0.003 ft
- Accuracy : +/-3 mm... +/-15 mm
- Blind Area : The end of antenna
- Beam Angle  $\alpha$  : 20° / 18° / 14° / 12° / 8° / 6°
- Measuring Interval : >1s (Dependent on configuration setting)
- Adjustment Time : >1s (Dependent on configuration setting)
- Ambient Temperature : -40~80 °C
- Relative Humidity : 0-95% RH
- Permittivity DK : >1.4
- Ambient Temp. Effect : 3 mm / 10 K, Max. 10 mm
- Gas Pressure Effect : 0.22 % (Air: 10 bar / 20 °C)
- Material
  - Antenna : PTFE / PFA / S.S. 316L
  - Process Connection : PP / PTFE / S.S. 304 / S.S. 316L / S.S +coated
  - Housing : Aluminum Alloy
- Process Connection : 1-1/2" NPT / G 1-1/2" Max. : 16 bar  
: Flange (DN50-DN150) Max. : 40 bar  
: Universal Flange (DN80-DN150) Max. : 3 bar
- Protection Class : IP67  
: Explosion Proof, Ex d IIC T6  
: Intrinsically Safe, Ex ia IIC T6



- Keypad : 4 internal keys for programming
- Unit : ft, in, m, cm, mm
- Process Temperature : -40~130 °C (Standard)  
: -40~230 °C (Optional)
- Process Pressure : -1.0~40 bar G (Max. )
- Max. Cable Length : 8 m (for single cavity housing)
- Power Supply : 16-26 VDC (2 wires)  
: 24 VDC ± 10% (4 wires)  
: 90-253 VAC, 50 / 60 Hz (4 wires)
- Power Consumption : 22.5 mA / 1W (Max. )
- Current Output : 4-20 mA (2 wires, 4 wires)  
Load : Rohm=(VDC-16) \* 50  
Resolution : 1.6  $\mu$ A  
Alarm Current : No change / 20.5 mA / 22 mA / 3.9 mA
- Damping : 0-40 s
- Communication : HART signal (Compatible) (Standard)  
: RS485 (MODBUS Protocol) (Optional)
- Data Storage : Operation parameters and totalization date are stored by EEPROM for more than 10 years
- EMI / RFI Effect : Follow SAMA PMC 33.1 from 20 to 1000 MHz and for field strengths up to 30 V/m
- Vibration Resistance : 20-2000 Hz, 1 (m/s<sup>2</sup>)/Hz
- Cable Entry : Standard: M20, Option: 1/2" NPTF



**WIRING DIAGRAM**

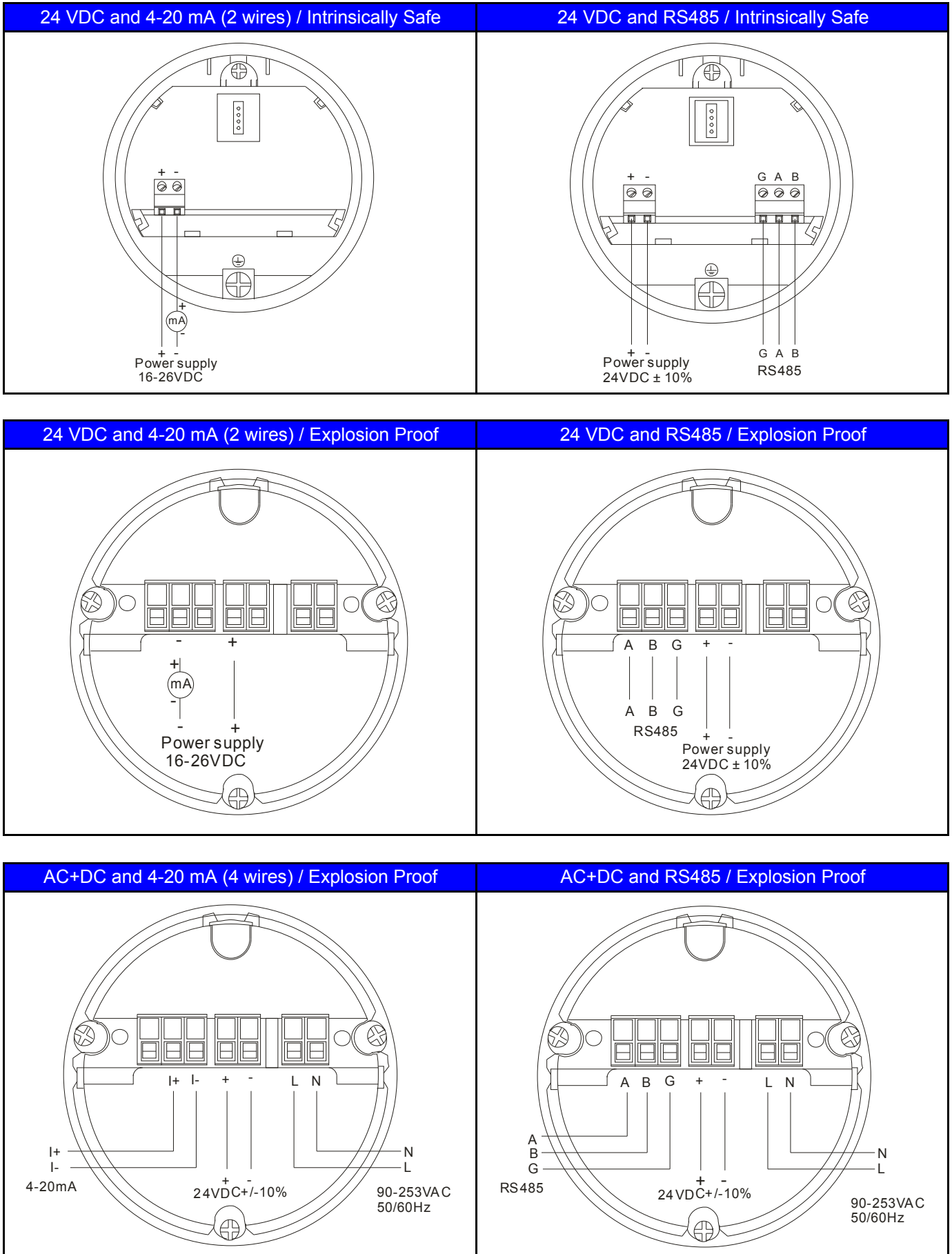

**➤ DIMENSIONS**

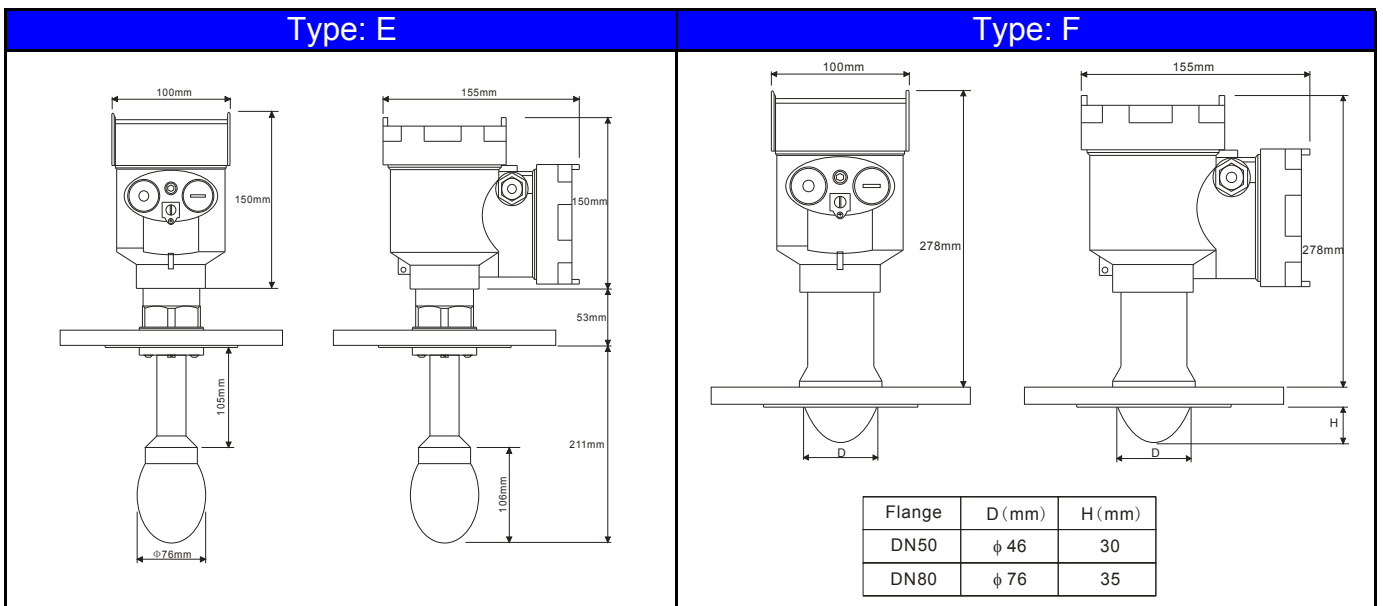
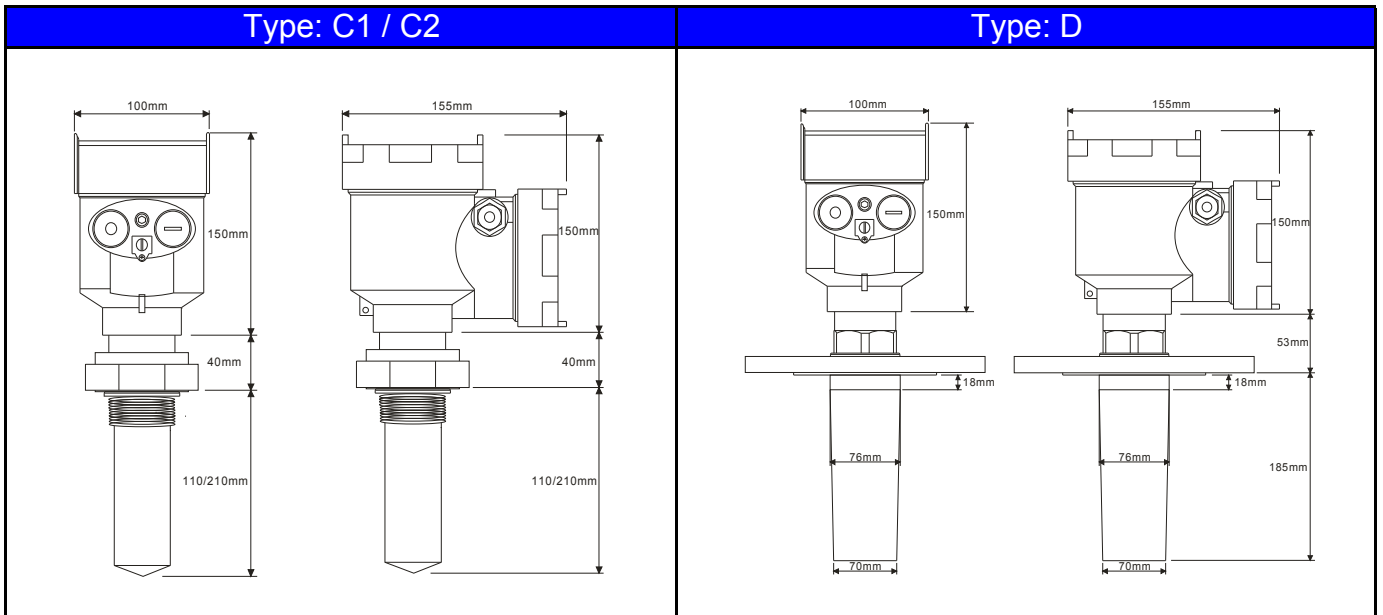
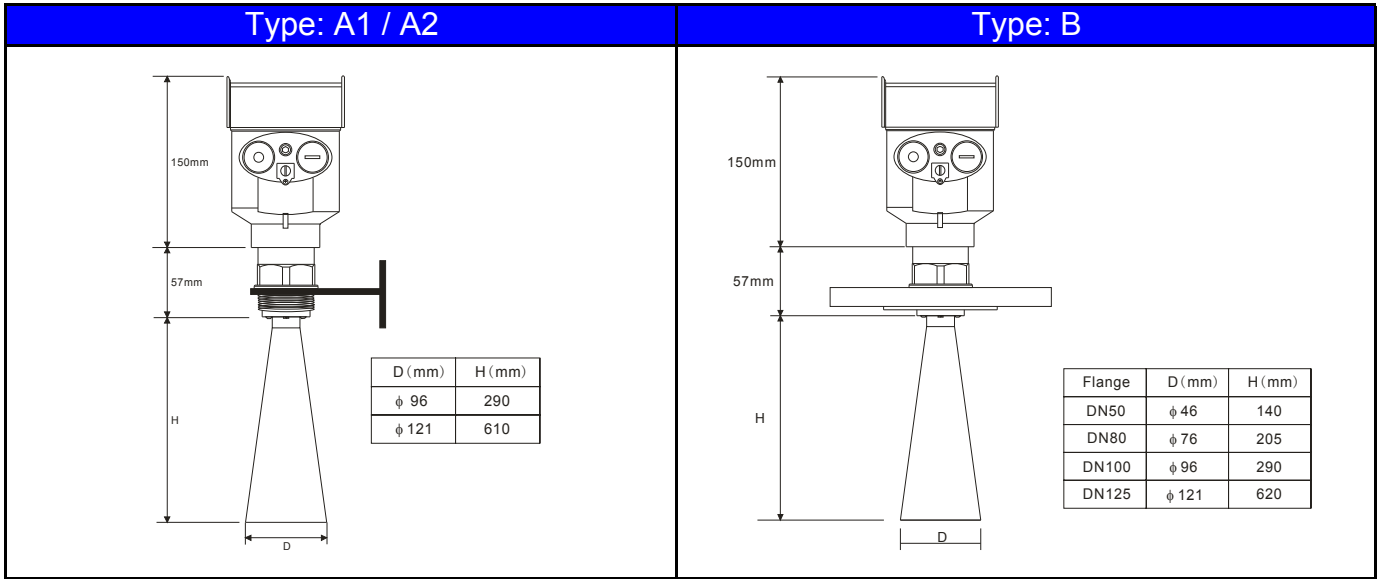

**➤ DIMENSIONS & DISPLAY**

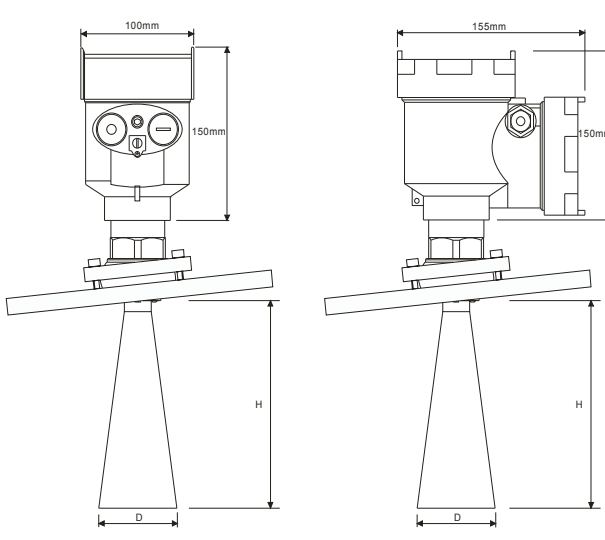
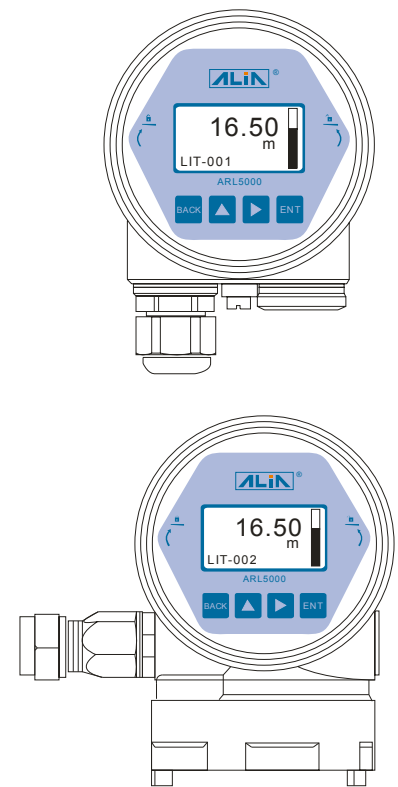
Type: H1 / H2 / H3	Display																
 <table border="1" style="margin: 20px auto; border-collapse: collapse;"> <thead> <tr> <th>Type</th> <th>Flange</th> <th>D (mm)</th> <th>H (mm)</th> </tr> </thead> <tbody> <tr> <td>H1</td> <td>DN80</td> <td>φ 76</td> <td>205</td> </tr> <tr> <td>H2</td> <td>DN100</td> <td>φ 96</td> <td>290</td> </tr> <tr> <td>H3</td> <td>DN125</td> <td>φ 121</td> <td>610</td> </tr> </tbody> </table>	Type	Flange	D (mm)	H (mm)	H1	DN80	φ 76	205	H2	DN100	φ 96	290	H3	DN125	φ 121	610	
Type	Flange	D (mm)	H (mm)														
H1	DN80	φ 76	205														
H2	DN100	φ 96	290														
H3	DN125	φ 121	610														

**➤ BEAM ANGLE**

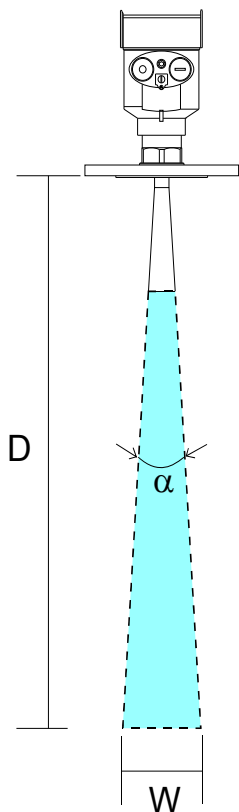

Antenna Size	φ 46 mm	φ 46 mm	φ 76 mm	φ 76 mm	φ 96 mm	φ 121 mm
Beam Angle α	20°	18°	14°	12°	8°	6°

Distance D	Beam Angle Diameter (W)					
3 m	1.06 m	0.95 m	0.74 m	0.63 m	0.42 m	0.31 m
6 m	2.12 m	1.90 m	1.47 m	1.26 m	0.84 m	0.63 m
9 m	3.17 m	2.85 m	2.21 m	1.89 m	1.26 m	0.94 m
12 m	4.23 m	3.80 m	2.95 m	2.52 m	1.68 m	1.26 m
15 m		4.75 m	3.68 m	3.15 m	2.10 m	1.57 m
20 m		6.34 m	4.91 m	4.20 m	2.80 m	2.10 m
25 m		7.92 m		5.26 m	3.50 m	2.62 m
30 m		9.50 m		6.31 m	4.20 m	3.14 m
35 m					4.89 m	3.67 m
40 m					5.59 m	4.20 m
45 m					6.29 m	4.72 m
50 m					6.99 m	5.24 m
55 m					7.69 m	5.76 m
60 m					8.39 m	6.29 m
65 m					9.09 m	6.81 m
70 m					9.79 m	7.34 m

MODEL & SPECIFICATION

Type: ARL5000-A Application: Rivers and Lakes Liquid



ARL5000-A Series					
Example: ARL5000-A2-GTN					
ARL5000-A	X	-X	X	X	Description
Type	1				Range: 0-30 m Accuracy: +/-5 mm
	2				Range: 0-70 m Accuracy: +/-15 mm
Flange Size		-G			Thread: G1-1/2" _ Beam Angle $\alpha$ : 8° _ Antenna Size: $\phi$ 96
		-P			Thread: 1-1/2" NPT _ Beam Angle $\alpha$ : 8° _ Antenna Size: $\phi$ 96
		-4			4" (DN100) _ Beam Angle $\alpha$ : 8° _ Antenna Size: $\phi$ 96
		-5			5" (DN125) _ Beam Angle $\alpha$ : 6° _ Antenna Size: $\phi$ 121 (Only Type 2)
		-6			6" (DN150) _ Beam Angle $\alpha$ : 6° _ Antenna Size: $\phi$ 121 (Only Type 2)
Material		T			Thread Material: S.S. 304, Antenna Material: S.S. 316L
		4			Flange Material: S.S. 304, Antenna Material: S.S. 316L
		L			Flange Material: S.S. 316L, Antenna Material: S.S. 316L
Max. temperature / Pressure				N	Temp. : -40~100 °C, Pressure: Atmospheric
<b>Please turn to option of Process Connection And Transmitter for model selection</b>					

Type: ARL5000-B Application: General Liquid



ARL5000-B Series					
Example: ARL5000-B1-4LN					
ARL5000-B	X	-X	X	X	Description
Type	1				Range: 0-30 m Accuracy: +/-3 mm
Flange Size		-G			Thread: G1-1/2" _ Beam Angle $\alpha$ : 18° _ Antenna Size: $\phi$ 46
		-P			Thread: 1-1/2" NPT _ Beam Angle $\alpha$ : 18° _ Antenna Size: $\phi$ 46
		-2			2" (DN50) _ Beam Angle $\alpha$ : 18° _ Antenna Size: $\phi$ 46
		-3			3" (DN80) _ Beam Angle $\alpha$ : 12° _ Antenna Size: $\phi$ 76
		-4			4" (DN100) _ Beam Angle $\alpha$ : 8° _ Antenna Size: $\phi$ 96
		-5			5" (DN125) _ Beam Angle $\alpha$ : 6° _ Antenna Size: $\phi$ 121
		-6			6" (DN150) _ Beam Angle $\alpha$ : 6° _ Antenna Size: $\phi$ 121
Material			N	Thread Material: S.S. 304, Antenna Material: S.S. 316L	
			4	Flange Material: S.S. 304, Antenna Material: S.S. 316L	
			L	Flange Material: S.S. 316L, Antenna Material: S.S. 316L	
Max. temperature / Pressure				N	Temp. : -40~130 °C, Pressure: -1.0~40 bar <b>*Note</b>
				H	Temp. : -40~230 °C, Pressure: -1.0~16 bar <b>*Note</b>
<b>Please turn to option of Process Connection And Transmitter for model selection</b>					

**Note:** The maximum pressure is also related to flange specifications and thickness.

Thread type: Max. 16 bar

MODEL & SPECIFICATION

Type: ARL5000-C Application: Corrosive Liquid



ARL5000-C Series					
Example: ARL5000-C1-GNN					
ARL5000-C	X	-X	X	X	Description
Type	1				Range: 0-10 m Accuracy : +/-5 mm, Antenna length: 110 mm
	2				Range: 0-10 m Accuracy : +/-5 mm, Antenna length: 210 mm
Flange Size		-G			Thread: G1-1/2" _ Beam Angle $\alpha$ : 20° _ Antenna Size: $\phi$ 46
		-P			Thread: 1-1/2" NPT _ Beam Angle $\alpha$ : 20° _ Antenna Size: $\phi$ 46
		-2			2" (DN50) _ Beam Angle $\alpha$ : 20° _ Antenna Size: $\phi$ 46
		-3			3" (DN80) _ Beam Angle $\alpha$ : 20° _ Antenna Size: $\phi$ 46
		-4			4" (DN100) _ Beam Angle $\alpha$ : 20° _ Antenna Size: $\phi$ 46
		-5			5" (DN125) _ Beam Angle $\alpha$ : 20° _ Antenna Size: $\phi$ 46
		-6			6" (DN150) _ Beam Angle $\alpha$ : 20° _ Antenna Size: $\phi$ 46
Material			N		Thread Material: PTFE, Antenna Material: PTFE
			P		Flange Material: PP, Antenna Material: PTFE
			F		Flange Material: PTFE, Antenna Material: PTFE
Max. temperature / Pressure				N	Temp. : -40~130 °C, Pressure: -1.0~3.0 bar <b>*Note</b>
<b>Please turn to option of Process Connection And Transmitter for model selection</b>					

**Note:** Maximum pressure is irrelevant to thread size, Flange specification and flange thickness.

Type: ARL5000-D Application: Corrosive or Vapor Liquid



ARL5000-D Series					
Example: ARL5000-D1-4LN					
ARL5000-D	X	-X	X	X	Description
Type	1				Range: 0-20 m Accuracy: +/-3 mm
Flange Size		-3			3" (DN80) _ Beam Angle $\alpha$ : 14° _ Antenna Size: $\phi$ 76
		-4			4" (DN100) _ Beam Angle $\alpha$ : 14° _ Antenna Size: $\phi$ 76
Material			4		Flange Material: S.S. 304+PFA, Antenna Material: PFA
			L		Flange Material: S.S. 316L+PFA, Antenna Material: PFA
Max. temperature / Pressure				N	Temp. : -40~130 °C, Pressure: 10 bar <b>*Note</b>
<b>Please turn to option of Process Connection And Transmitter for model selection</b>					

**Note:** The maximum pressure is also related to flange specifications and thickness.

MODEL & SPECIFICATION

Type: ARL5000-E Application: Vapor Liquid



ARL5000-E Series					
Example: ARL5000-E1-4LN					
ARL5000-E	X	-X	X	X	Description
Type	1				Range: 0-15 m Accuracy : +/-3 mm
Flange Size	-3				3" (DN80) _ Beam Angle $\alpha$ : 12° _ Antenna Size: $\phi$ 76
	-4				4" (DN100) _ Beam Angle $\alpha$ : 12° _ Antenna Size: $\phi$ 76
	-5				5" (DN125) _ Beam Angle $\alpha$ : 12° _ Antenna Size: $\phi$ 76
	-6				6" (DN150) _ Beam Angle $\alpha$ : 12° _ Antenna Size: $\phi$ 76
Material			4	Flange Material: S.S. 304, Antenna Material: S.S. 304+PTFE	
			L	Flange Material: S.S. 316L, Antenna Material: S.S. 304+PTFE	
Max. temperature / Pressure				N	Temp. : -40~130 °C, Pressure: 10 bar <b>*Note</b>
Please turn to option of Process Connection And Transmitter for model selection					

**Note: The maximum pressure is also related to flange specifications and thickness.**

Type: ARL5000-F Application: Sanitary / Strong / Corrosive Liquid



ARL5000-F Series					
Example: ARL5000-F1-4PN					
ARL5000-F	X	-X	X	X	Description
Type	1				Range: 0-20 m Accuracy: +/-3 mm
Flange Size	-2				2" (DN50) _ Beam Angle $\alpha$ : 18° _ Antenna Size: $\phi$ 46
	-3				3" (DN80) _ Beam Angle $\alpha$ : 12° _ Antenna Size: $\phi$ 76
	-4				4" (DN100) _ Beam Angle $\alpha$ : 12° _ Antenna Size: $\phi$ 76
	-5				5" (DN125) _ Beam Angle $\alpha$ : 12° _ Antenna Size: $\phi$ 76
	-6				6" (DN150) _ Beam Angle $\alpha$ : 12° _ Antenna Size: $\phi$ 76
Material			P	Flange Material: S.S. 304+PTFE, Antenna Material: PTFE	
			F	Flange Material: S.S. 316L+PTFE, Antenna Material: PTFE	
Max. temperature / Pressure				N	Temp. : -40~130 °C, Pressure: 25 bar <b>*Note</b>
				H	Temp. : -40~200 °C, Pressure: 16 bar <b>*Note</b>
Please turn to option of Process Connection And Transmitter for model selection					

**Note: The maximum pressure is also related to flange specifications and thickness, and the flange thickness can not be 12 mm and with standard of 22 mm.**

**MODEL & SPECIFICATION**

Type: ARL5000-H Application: Easily Condensed or Dust Process Vessels



ARL5000-H Series						
Example: ARL5000-H1-4L-UF-NN						
ARL5000-H	X	-X	X	-XX	-XX	Description
Type	1					Range: (Dust: 0-10 m / Particle: 0-12 m) Accuracy: +/-15 mm
	2					Range: (Dust: 0-20 m / Particle: 0-25 m) Accuracy: +/-15 mm
	3					Range: (Dust: 0-35 m / Particle: 0-40 m) Accuracy: +/-15 mm
Flange Size		-3				3" (DN80) _ Beam Angle $\alpha$ : 12° _ Antenna Size: $\phi$ 76 (Type: 1)
		-4				4" (DN100) _ Beam Angle $\alpha$ : 8° _ Antenna Size: $\phi$ 96 (Type: 2)
		-5				5" (DN125) _ Beam Angle $\alpha$ : 6° _ Antenna Size: $\phi$ 121 (Type: 3)
		-6				6" (DN150) _ Beam Angle $\alpha$ : 6° _ Antenna Size: $\phi$ 121 (Type: 3)
Material			4			Flange Material: S.S. 304, Antenna Material: S.S. 316L
			L			Flange Material: S.S. 316L, Antenna Material: S.S. 316L
Flange Type				-UF		Universal Flange, Max. Pressure: 3 bar <b>*Note</b>
				-FF		Fixed Flange, Max. Pressure: 40 bar <b>*Note</b>
Max. temperature / Pressure And Other				-NN		Temp. : -40~130 °C, Pressure: 40 bar <b>*Note</b>
				-HH		Temp. : -40~230 °C, Pressure: 16 bar <b>*Note</b>
				-PD		Purge device (Used only in Type: H)
				-DP		Sensor Dust Protector (Used only in Type: H, Material: PTFE)
<b>Please turn to option of Process Connection And Transmitter for model selection</b>						

**Note:** Please select the minimum pressure value for each option, which is also related to flange specifications.

Process Connection And Transmitter

Example: -2NN-ANN-NN						
	-X	XX	-X	XX	-XX	Description
Process Connection	-N					Thread
	-1					PN10
	-2					PN16
	-3					PN25
	-4					PN40
	-A					ANSI 150#
	-B					ANSI 300#
	-J					JIS 10K
	-K					JIS 20K
	-L					JIS 40K
Flange thickness		NN				Thread or Flange Thickness: 12 mm,
		FF				Flange Thickness: 22 mm, Only for ARL5000-F
		ST				International standard flange thickness
Power Supply / Output			-A			16-26 VDC / 4-20 mA (2 wires) with HART
			-B			24 VDC $\pm$ 10% / RS485
			-C			90-253 VAC or 24 VDC $\pm$ 10% / 4-20 mA (4 wires) with HART
			-D			90-253 VAC or 24 VDC $\pm$ 10% / RS485
Protection Class				NN		IP67
				IT		Intrinsically Safe, Ex ia IIC T6 (Used only in Power supply / Output: A / B)
				EX		Explosion Proof, Ex d IIC T6 (Used only in the double cavity housing)
Option				-NN		None
				-PT		Cable Entry: 1/2" NPTF
				-RM		The remote converter, cable of 8 m (Used only in 24 VDC and without Ex d)