

## GENERAL

**ALIAMAG** The AMF100HM Series is an insertion type electromagnetic flowmeter ideal for conductive liquids. It comes in sizes from 150-6000 mm.

AMF100HM is widely used for tap-water, waste water, food & beverage, pulp & paper and many other industrial fluid.

AMF100HM Series electromagnetic flowmeter could be used in compact or remote type with AMC Series converter of electromagnetic flowmeter.

## FEATURES

- Light and compact version
- Measuring range up to 12 m/s
- Suitable for permanent or temporary installation
- Price virtually independent of pipe diameter
- Hot-tap into pressurised pipe
- Good accuracy over wide operating flow range
- With Forward / Reverse flow rate measurement function
- Stable calibration and reliable operation

## STANDARD SPECIFICATION

- |                      |  |                        |  |
|----------------------|--|------------------------|--|
| ● Size               | : 150, 200, 250, 300, 350, 400, 450<br>500, 600, 700..... 6000 mm  | ● Cable Entry          | : Standard: M20 Option: 1/2"NPTF   |
| ● Measuring Range    | : Velocity 0-0.25 m/s Min.<br>0-12 m/s Max.  | ● Grounding Resistance | : Must be less than 10 Ω   |
| ● Material           | Protection Tube : Stainless Steel 316<br>Screw : Stainless Steel 316<br>Electrode : Stainless Steel 316L<br>Cap : PTFE<br>Ball Valve : Stainless Steel 316 (Optional)<br>Hot-Tap Tool / Kit : Stainless Steel 304 (Optional) | ● Accuracy             | : +/-2% of reading (Velocity ≥ 0.5 m/s)<br>: +/-0.8% of Full Scale (F.S. > 2 m/s)<br>: +/-0.01 m/s (Velocity < 0.5 m/s)                          |
| ● Mounting           | : Compact or remote  | ● Repeatability        | : +/-0.4% of reading   |
| ● Process Connection | Threaded : Threaded, 2" BSP Female<br>Flange : Flange, JIS / ANSI / DIN  | ● Process Temperature  | : -10~80 °C  |
| ● Installation       | : Direct insert to the pipe<br>: Insert with Ball Valve<br>: Hot-Tap into pressurised pipe   | ● Ambient Temperature  | : -25~70 °C  |
| ● Protection Class   | : IP67<br>: IP68 (Submersible)   | ● Max. Pressure        | : 10 kgf/cm <sup>2</sup>   |
| ● Explosion Proof    | : Ex d (ib) ibq IIB T5<br>(with AMC3200HM only)  | ● Conductivity         | : More than 10 uS/cm   |
|                      |  | ● Weight               | : 3-10 kg  |
|                      |  | ● Coil Resistance      | : 70-98 Ω  |
|                      |  | ● Sensor Diameter      | : 45 mm  |
|                      |  | ● Sensor Length        | : 310 mm (for 150-600 mm pipe ID)<br>550 mm (for 600-2400 mm pipe ID)<br>800 mm (for 2400-4200 mm pipe ID)<br>1050 mm (for 4200-6000 mm pipe ID) |



**➤ DIMENSIONS**

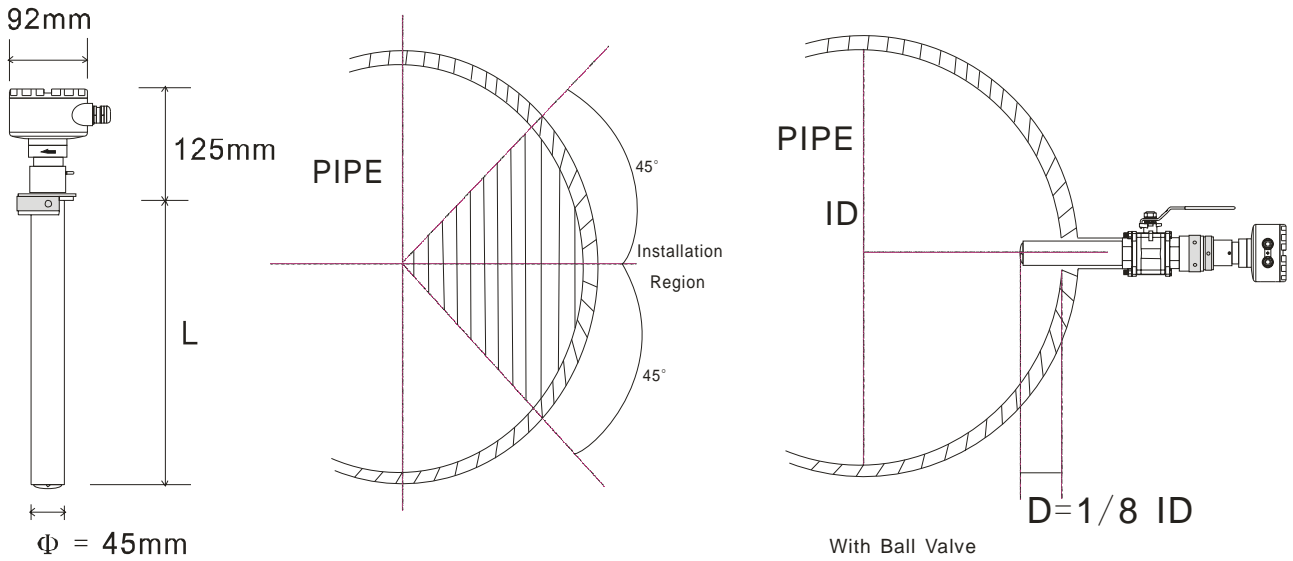

L (mm)	Direct install (Thread)	Direct install (Flange)	Install with Ball valve	Hot-Tap into pressurised pipe
310	DN 150-1800 mm	DN 150-1000 mm	DN 150-400 mm	DN 150-600 mm
550	DN 1800-3800 mm	DN 1000-2800 mm	DN 400-2200 mm	DN 600-2400 mm
800	DN 3800-6000 mm	DN 2800-4800 mm	DN 2200-4200 mm	DN 2400-4200 mm
1050		DN 4800-6000 mm	DN 4200-6000 mm	DN 4200-6000 mm

**➤ HOT-TAP & UNDER PRESSURE INSTALLATION KIT**

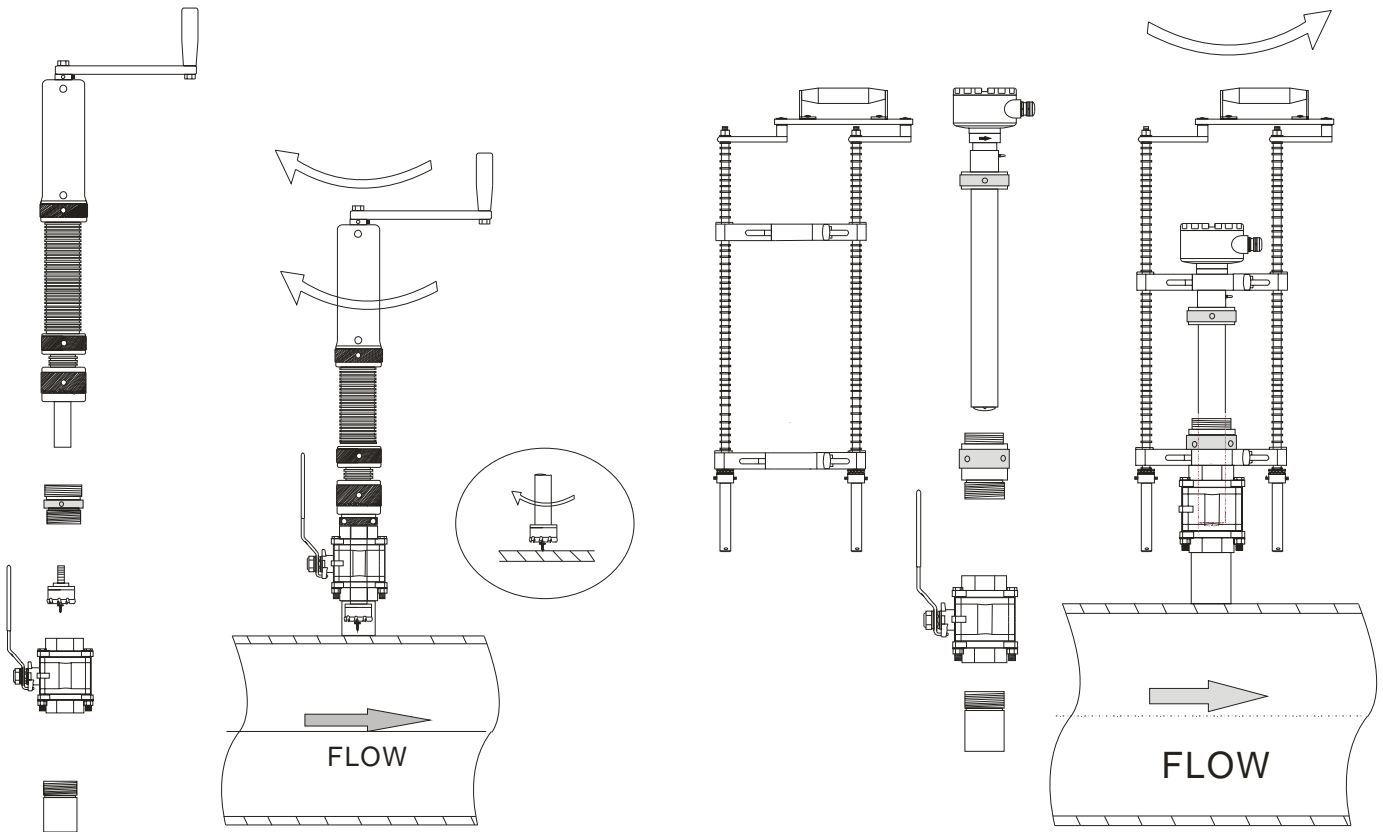

Hot-Tap Machine

Under Pressure Installation Kit

**INSTALLATION**

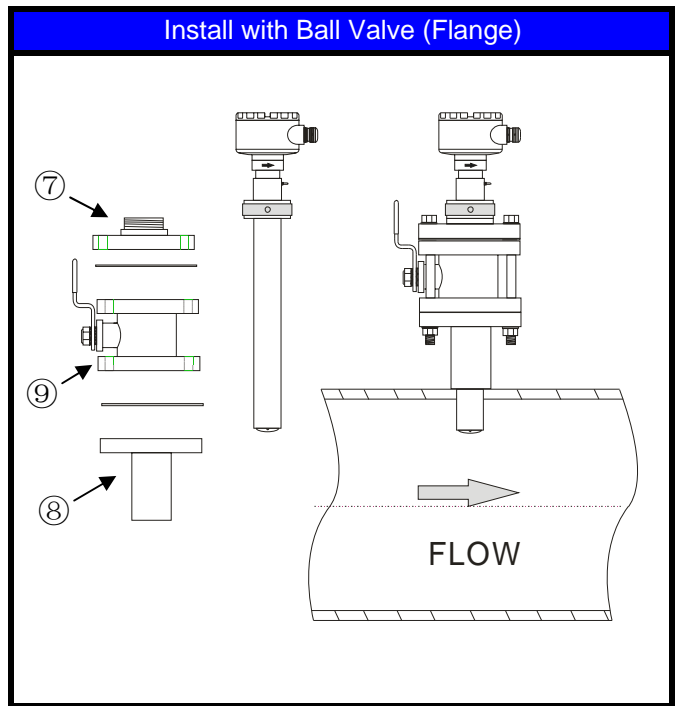
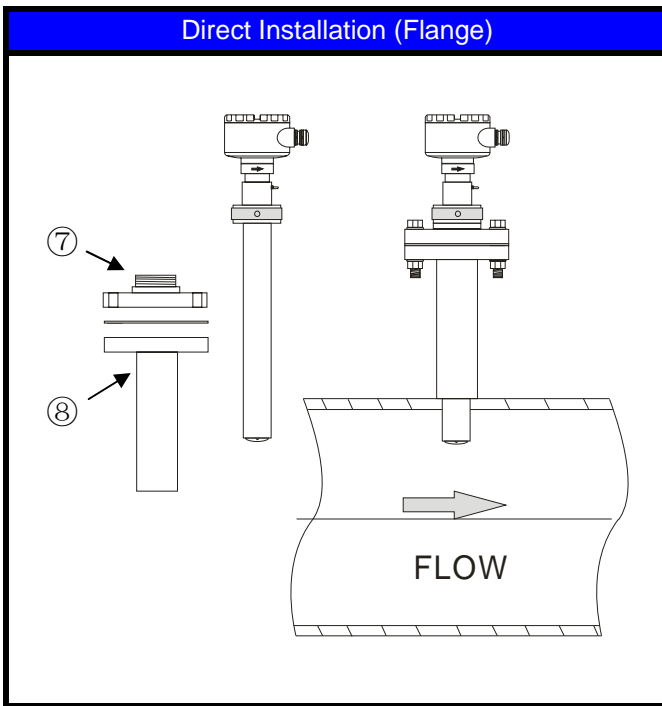
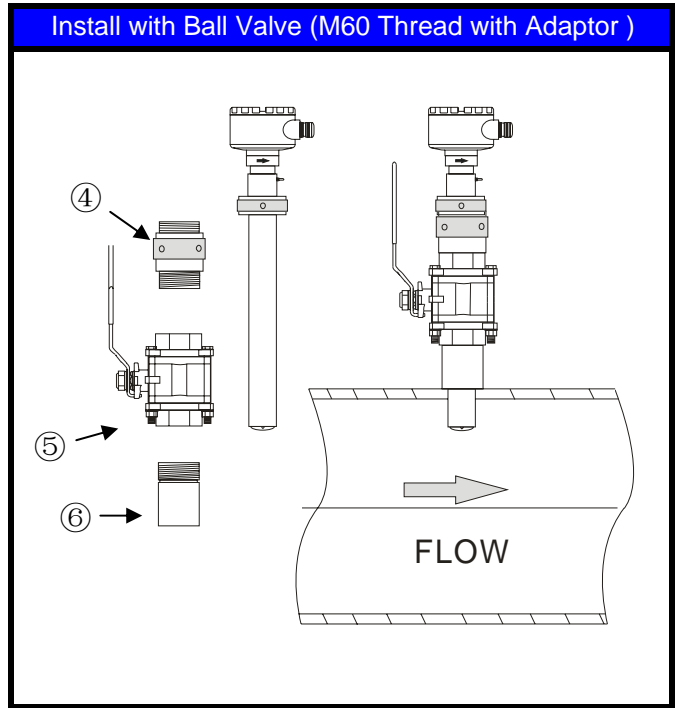
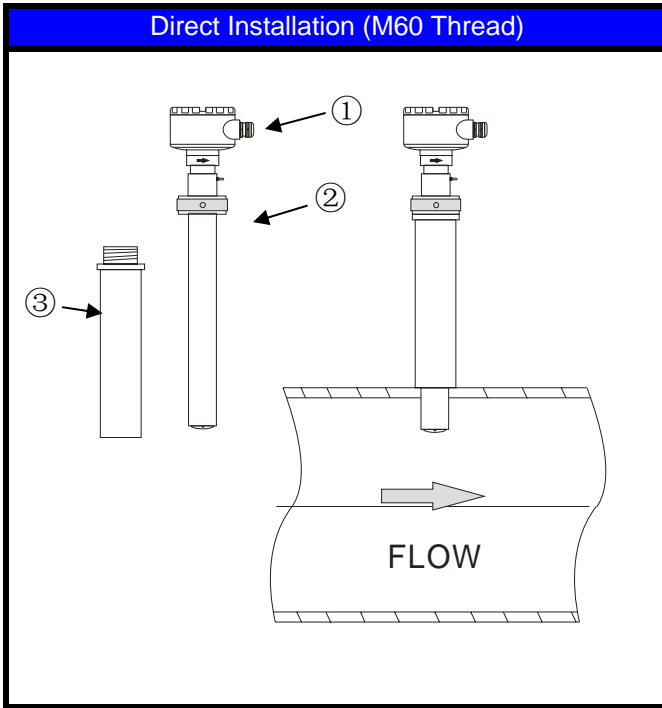

①	Junction Box	Cable Entry PG11
②	Nut	M60 Thread (Female)
③	Extension Tube 1	M60 Thread (Male) / Welding (Optional)
④	Adapter 1	M60 Thread (Male) / 2" BSP (Male)
⑤	Ball Valve	2" BSP Female
⑥	Extension Tube 2	2" BSP (Male) / Welding (Optional)
⑦	Adapter 2	M60 Thread (Male) / Flange
⑧	Extension Tube 3	2" Flange / Welding (Optional)
⑨	Ball Valve	2" Flange End

**MODEL SELECTION GUIDE**

AMF100HM Series										
Example: AMF100HM-T0350-1SN8-020-SV/EX/PT										
AMF100HM-	X	XXXX	-X	X	X	X-	XXX	-XX	Description	
Fitting	T								Direct installation, M60 thread female	
	F								Flange	
Pipe Size	0150-6000									0150-6000 mm (Internal diameter)
Sensor Length	-1								310 mm	
	-2								550 mm	
	-3								800 mm	
	-4								1050 mm	
	-Z								Special length	
Electrode Material	S								Stainless Steel 316L	
	Z								Others	
Flange Specification	N								None	
	J								50A JIS 10K	
	A								2" ANSI 150#	
	P								DN50 PN10	
	Z								Others	
Protection Class	8-								Junction box IP67, Body IP68	
	9-								IP68 (Submersible, Remote with Converter Only)	
Installation & Cable Length	NNN								Compact Version (with AMC2100HM)	
	SSS								Compact Version (with AMC3200HM / AMC3200HME / AMC4000HM)	
	010-300								Remote Version, Cable 10-300 m	
Option	-NN								None	
	-SV								Stainless Steel 316 Ball Valve 2" BSP Female + Adapter 1	
	-FV								Stainless Steel 316 Ball Valve 2" Flange	
	-HM								Hot-Tap Machine	
	-EX								Explosion Proof, Ex d (ib) ibq IIB T5 (with AMC3200HM Only)	
	-PT								Cable Entry 1/2" NPTF	
	-PK								Under Pressure Installation Kit	
	-ET								Extension Tube	

The following information must be provided before order:

1. Pipe Inside Diameter (ID)
2. Pipe Outside Diameter (OD)
3. Pipe Material
4. Extension Length (L)
5. Flange Type or 2"BSPM
6. Fluid Name
7. Op. Temperature
8. Op. Pressure

